



**Models  
90 & 91**

## Features

- Small, rugged design suitable for installation where space is limited.
- Soft seat construction to assure positive shutoff.
- Low selection differential to allow precise control of switching.
- Fast response that is suitable for control in critical loops.
- Automatic switching that eliminates manual monitoring of signal pressure.

## Operating Principles

The Model 90 Low Pressure Selector Relay is designed to select the lower of two signal pressures to provide a continuous output pressure to a control device. The Model 90 is recommended for dead end or low flow service in critical applications such as control loops requiring precise, automatic monitoring of signal pressures.

The Model 91 High Pressure Selector Relay is designed to select the higher of two signal pressures, and to provide a continuous output pressure (or pressure range) to a controller. The ability to precisely control switching and pressure monitoring make the Model 91 the logical choice in dead end or low flow applications such as precision control loops.

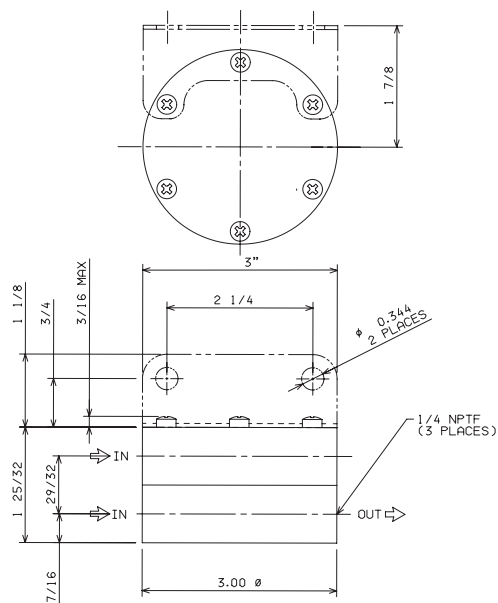
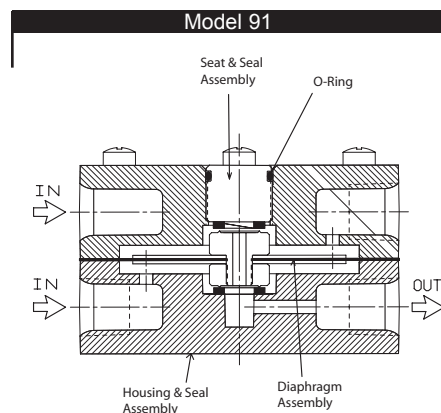
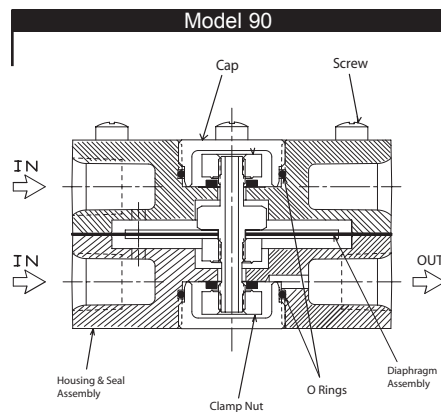

# Models 90 and 91 Low / High Pressure Selector Relay

## Technical Information

Flow Characteristics  
Fairchild Model 90052

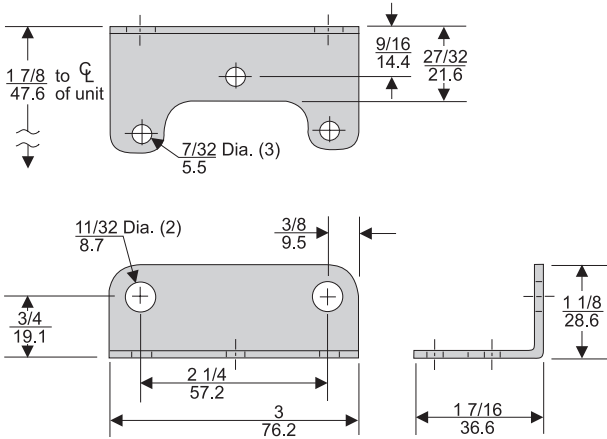
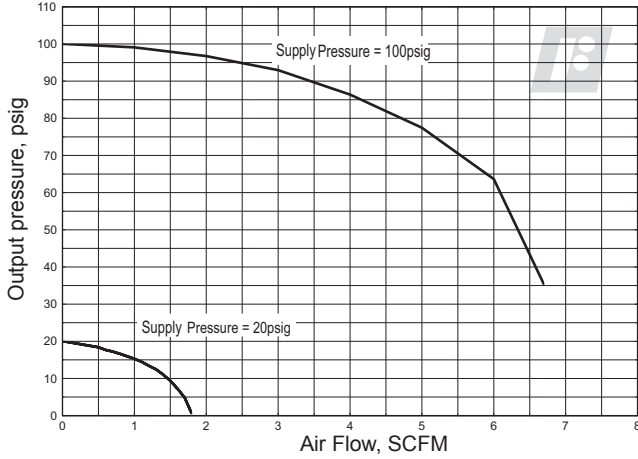

Mounting Bracket: 09921

## Model 90/91 Relay Kits & Accessories

Mounting Bracket Kit ..... 09921 (sold separately).....

## Specifications

### Maximum Signal Pressure

200 psig, [14.0 BAR], (1400 kPa)

### Minimum Switching Differential

Less than .1 psig, [.007 BAR], (.7 kPa)

### Maximum Differential between Signals

100 psig, [7.0 BAR], (700 kPa)

### Ambient Temperature Range

-40°F to +200°F, (-40°C to +93.3°C)

### Materials of Construction

Body ..... Aluminum Alloy  
Diaphragm..... Nitrile on Dacron  
Trim.....  
Brass.....

## Catalog Information

Catalog Number 9  05

### Models

90 Low Pressure Selector .....

0

91 High Pressure Selector .....

1

### Pipe Size

1/4" NPT .....

2

### Options

Fluorocarbon Elastomers .....

J

BSPT (Tapered).....

U

## Installation

Service Kits are available for the Model 90 and Model 91. Refer to the *Fairchild Model 90 and Model 91 Installation, Operation and Maintenance Instructions*, IS-30009091.